

EN CE IP65

Supplementary Instruction Manual for HOTSPOT-X22/X2
IR Heat Detector

Supplementary Instructions for HOTSPOT-X22/X2
Article number: 410-2410-018
Index: -EN-02
Release date: 20.03.23

– Translation –

Manufacturer:
GTE Industrieelektronik GmbH
Helmholtzstr. 21, 38-40
41747 Viersen
GERMANY

Support hotline: +49 2162 3703-0
E-Mail: support.adicos@gte.de

© 2024 GTE Industrieelektronik GmbH – This document and all figures contained may not be copied, changed, or distributed without explicit approval by the manufacturer!

Subject to technical changes!

ADICOS® is a registered trademarks of GTE Industrieelektronik GmbH.

Abstract

The Advanced Discovery System (ADICOS®) is used for early detection of fires in industrial environments. It is comprised of various, separate detector units. By parameterizing and arranging the detectors appropriately, the system fulfills a predefined detection goal. The ADICOS system ensures reliable early detection of embers and smoldering fires even in adverse environments.

The detectors of the HOTSPOT product series are equipped with thermal imaging sensors and use infrared measurement technology and intelligent signal analysis to detect all types of smoldering fires and open fires, even in the incipient stage. The fast response speed of 100 milliseconds enables the monitoring of conveyor belts or other conveyor systems, e.g. on moving embers.

The ADICOS HOTSPOT-X22/X2 is used for early and spatially resolved detection of fire flames and heat, and for ember detection. Possible fields of application are areas endangered by dust (ATEX zone 22) as well as by gas (ATEX zone 2).

Contents

1	About this Manual	5
1.1	Objective.	5
1.2	Explanation of Symbols.	5
1.3	Storing the Manual	5
2	Safety Instructions.	6
2.1	Intended Use	6
2.2	Standards and Regulations.	6
2.3	Personnel Qualification	7
2.4	Handling Electrical Voltage	7
2.5	Modification	7
2.6	Accessories and Spare Parts	7
3	Structure.	8
3.1	Overview.	8
3.2	Cable Assignment	9
4	Installation	10
4.1	Mounting on Mounting Plate.	10
4.2	Mounting on Mounting Bracket	11
4.3	Wiring	12
5	Commissioning.	12
6	Operation	12
7	Maintenance.	12
8	Disposal	12
9	Technical data	13
9.1	ID Plate	14
10	Appendix.	15
10.1	ADICOS Mounting Plate	15
10.2	ADICOS Mounting Bracket	16

1 About this Manual

1.1 Objective

This manual describes the special requirements on installation, wiring, commissioning, and operation of ADICOS detectors for explosive atmospheres of ATEX zone 22 and ATEX zone 2. They are exclusively addressed to knowledgeable specialist personnel (→ Chap. 2, Safety instructions).

1.2 Explanation of Symbols

This manual features a continuous structure for best possible comprehension. The following labels are used.

Warning signs

The following types of notes are used through this manual.

**DANGER!**

This combination of symbol and signal word indicates an immediately dangerous situation that will lead to death or severe injuries if not avoided.

**WARNING!**

This combination of symbol and signal word indicates a possibly dangerous situation that could lead to death or severe injuries if not avoided.

**Explosion protection**

This information type signals measures that must be implemented for maintaining the Explosion protection.

**Tips and recommendations**

Helpful tips and recommendations as well as information to ensure efficient and uninterrupted use.

1.3 Storing the Manual

Store this manual easily reachable and in direct vicinity of the detector system to enable use as needed.

2 Safety Instructions

ADICOS HOTSPOT-X22/X2 detectors for explosive atmospheres of ATEX zone 22 and ATEX zone 2 ensure operational safety assuming proper installation, commissioning, operation, and maintenance. For this purpose, it is absolutely required to completely read, understand, and follow this manual and the safety information contained.



WARNING!

Personal injury and property damage!

Incorrect installation and operating errors can cause death, serious injury and damage to industrial equipment.

- **Read the entire manual and follow the instructions!**



Explosion protection

When using ADICOS detectors in potentially explosive atmospheres, follow the specifications of the ATEX operating directive.

2.1 Intended Use

ADICOS HOTSPOT-X22/X2 are designated for the detection of fire scenarios in explosive atmospheres of ATEX zone 22 and ATEX zone 2. In this context, the operating parameters described in Chap. 9, »Technical Data« must be met. Any deviating use requires prior consultation with the manufacturer.

Compliance with this manual as well as all applicable country-specific provisions is also part of the intended use.

2.2 Standards and Regulations

The safety and accident prevention regulations applicable for the specific application must be observed during detector installation, commissioning, maintenance, and test.

The following standards and directives in their current version are of particular importance when handling potentially explosive atmospheres:

Standards and Regulations	Description
EN 60079-0	Explosive atmospheres - Part 0: Equipment - General requirements
EN 60079-7	Explosive atmospheres - Part 7: Equipment protection by increased safety „e“
EN 60079-15	Explosive atmospheres - Part 15: Equipment protection by type of protection „n“
EN 60079-31	Explosive atmospheres - Part 31: Equipment dust ignition protection by enclosure „t“
EN 60529	Degrees of protection provided by enclosures (IP Code)
2014/34/EU	ATEX product directive (about equipment and protective systems intended for use in potentially explosive atmospheres)
1999/92/EG	ATEX operating directive (on safety and health protection of workers potentially at risk from explosive atmospheres)

2.3 Personnel Qualification

Any work on ADICOS AAB-X22/X2 may only be performed by qualified personnel. Persons, who can perform work on electrical systems and recognize possible dangers based on their professional education, knowledge, and experience as well as knowledge of the applicable provisions, are considered qualified personnel.

**WARNING!****Personal injury and property damage!**

Improperly performed work on and with the device can lead to malfunctions.

- **Installation, startup, parameterization and maintenance may be performed only by authorized and properly trained personnel.**

2.4 Handling Electrical Voltage

**DANGER!****Risk of explosion by electrical voltage in potentially explosive atmospheres!**

The electronics of ADICOS HOTSPOT-X22/X2 detectors requires an electrical voltage that can trigger an explosion in potentially explosive atmospheres.

- **Do not open enclosure!**
- **De-energize the entire detector system and secure against unintentionally reactivation for all wiring work!**

2.5 Modifications

**WARNING!****Property damage or detector failure by any form of unauthorized modification!**

Any form of unauthorized modification or extension can lead to a failure of the detector system. The warranty claim expires.

- **Never make unauthorized modifications on your own authority.**

2.6 Accessories and Spare Parts

**WARNING!****Property damage due to short circuit or failure of the detector system**

The use of parts other than the manufacturer's original spare parts and original accessories may result in property damage due to short circuits.

- **Only use original spare parts and original accessories!**
- **Original spare parts and accessories may only be installed by trained specialist personnel.**
- **Qualified personnel are persons as described in Chap. 2.3.**

3 Structure

3.1 Overview

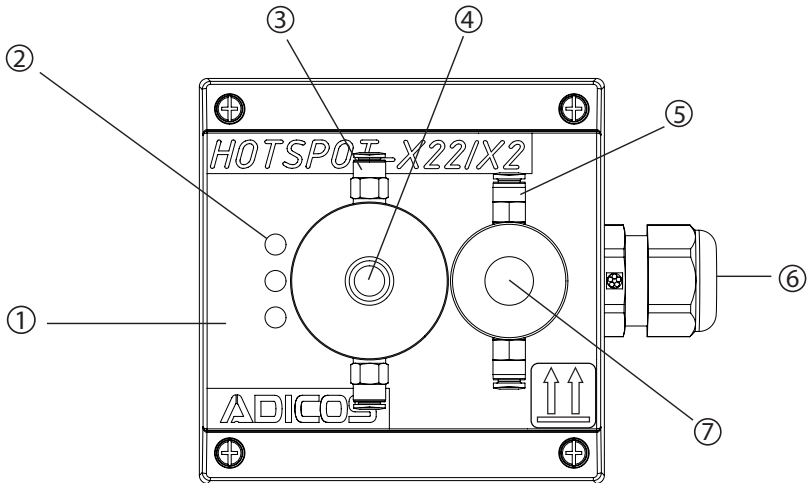

No.	Description
①	Enclosure
②	Display elements
③	Purge air adapter IR-Sensor
④	IR-Sensor
⑤	Purge air adapter camera
⑥	Explosion Proof cable gland
⑦	Camera

3.2 Cable Assignment

3.2.1 12-pin cable; LEONI KERPEN ICONBASE

Wire	Color	Signal	Limit value contact
1	black	Operating voltage 21.6 ... 40 V (DC) non polarized	
1	white		
2	black	Relay output X6 e	Alarm NO ¹
2	white	Relay output X6 a	Alarm NO ¹
3	black	Relay output X7 a	Fault NC
3	white	Relay output X7 e	Fault NC
4	black	M-Bus max. 40 V non-polarised	
4	white		

¹ with series resistor

Option analog signal

Wire	Color	Signal	Analog signal
5	black	Analog Current	4 ... 20 mA
5	white	Analog Current	4 ... 20 mA
6	black		
6	white		

Option Fire panel interface

Wire	Color	Siemens FDnet	Bosch LSNi
5	black	FDnet (+)	LSN a in
5	white	FDnet-A (-)	LSN b1 in
6	black	FDnet (+)	LSN a out
6	white	FDnet-B (-)	LSN b2 out

Option pre-alarm

Wire	Color	Auxiliary relay
5	black	-
5	white	NC
6	black	NO
6	white	C

3.2.2 12-pin cable OELFLEX 415CP

Wire	Signal	Limit value contact
1	Operating voltage DC 21.6 ... 40 V non-polarised	
2		
3	M-Bus max. 40 V non-polarised	
4		
5	Relay output X6 e	Alarm NO ¹
6	Relay output X6 a	Alarm NO ¹
7	Relay output X7 a	Fault NC
8	Relay output X7 e	Fault NC

¹ with series resistor**Option analog signal**

Wire	Signal	Analog signal
9	Analog current	4 ... 20 mA
10	Analog current	4 ... 20 mA
11		
12		

Option Fire panel interface

Wire	Siemens FDnet	Bosch LSNi
9	FDnet-A (-)	LSN b1 in
10	FDnet (+)	LSN a in
11	FDnet-B (-)	LSN b2 out
12	FDnet (+)	LSN a out

Option pre-alarm

Wire	Auxiliary relay
9	Normally closed
10	-
11	Common
12	Normally open

4 Installation

4.1 Mounting on Mounting Plate

**WARNING!**

Risk of explosion in hazardous areas due to electrical voltage.

ADICOS HOTSPOT-X22/X2 detectors must be mounted with closed enclosure.

- **Do not open enclosure!**
- **Use ADICOS mounting plate!**

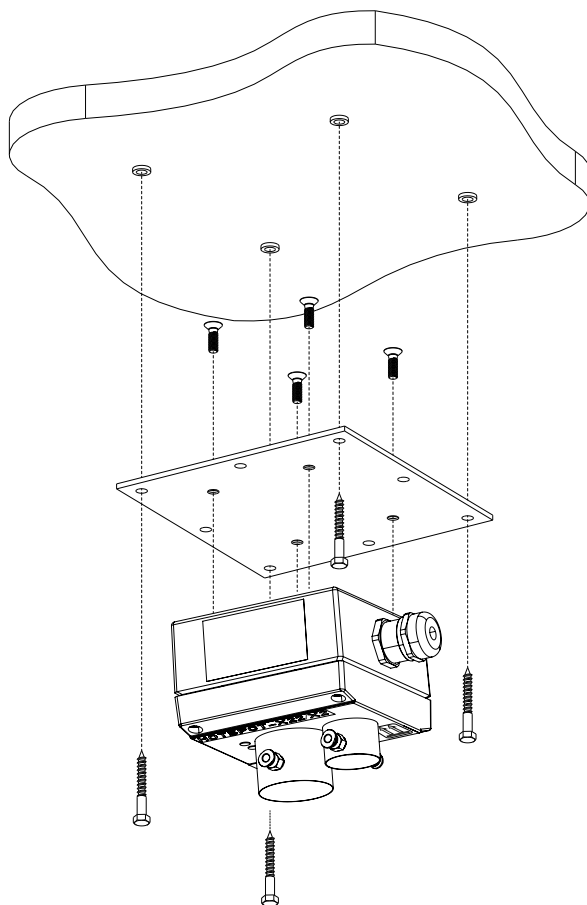

4.2 Mounting on Mounting Bracket



WARNING!

Risk of explosion in hazardous areas due to electrical voltage.

ADICOS HOTSPOT-X22/X2 detectors must be mounted with closed enclosure.

- **Do not open enclosure!**
- **Use ADICOS mounting foot!**

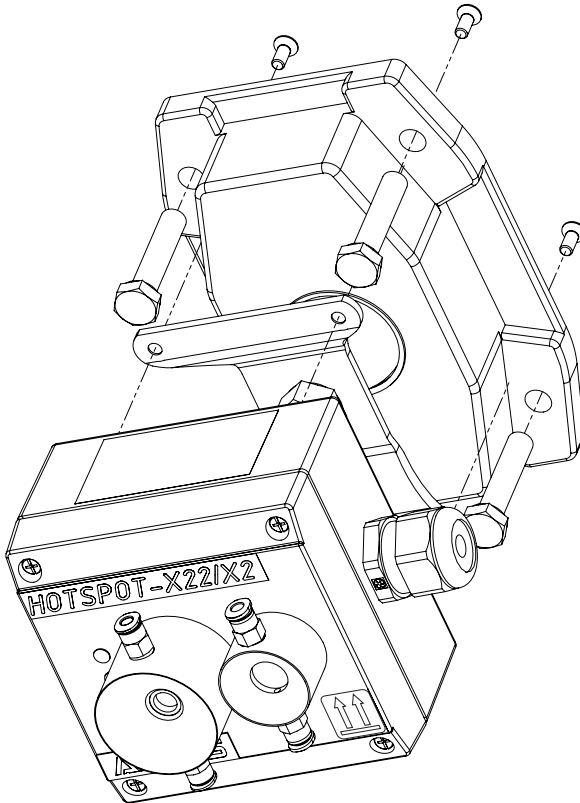

4.3 Wiring

Wiring according to chapter 3.2.



DANGER!

Risk of explosion in hazardous areas due to electrical voltage.

The electronics of the ADICOS HOTSPOT-X22/X2 detectors requires an electrical voltage that can trigger an explosion in potentially explosive atmospheres.

- **Do not open enclosure!**
- **De-energize the entire detector system and secure against unintentionally reactivation for all wiring work!**
- **In the case of wiring within potentially explosive atmospheres, only use explosion-proof junction boxes with respective approval!**
- **Do not bend connection cable! Observe minimum bending radius!**
(→ Chap. 9, Technical Data)

5 Commissioning



DANGER!

Risk of explosion in hazardous areas due to electrical voltage.

The electronics of the ADICOS HOTSPOT-X22/X2 detectors requires an electrical voltage that can trigger an explosion in potentially explosive atmospheres.

- **Prior to switching on, check that all detectors are properly mounted and wired!**

6 Operation



DANGER!

Risk of explosion in hazardous areas due to electrical voltage.

The electronics of the ADICOS HOTSPOT-X22/X2 detectors requires an electrical voltage that can trigger an explosion in potentially explosive atmospheres.

- **Never open the enclosure or loosen the cable gland during operation!**

7 Maintenance



DANGER!

Risk of explosion in hazardous areas due to electrical voltage.

The electronics of the ADICOS HOTSPOT-X22/X2 detectors requires an electrical voltage that can trigger an explosion in potentially explosive atmospheres.

- **Do not open enclosure!**
- **De-energize the entire detector system and secure against unintentionally reactivation for all wiring work!**
- **Replace the closed detector including connection cable only!**

8 Disposal

Return the device to the manufacturer when it reaches the end of its serviceable life. The manufacturer will ensure that the components are disposed of properly, in an environmentally friendly manner.



9 Technical data

General		
Model		HOTSPOT-X22/X2
Item No.		410-2001-130
Enclosure dimensions	mm	128 x 100 x 90 (Length x Width x Depth) (Length: cable gland included)
Weight (incl. 7 meter cable)	kg	2
Degree of protection		IP 65
Enclosure		Aluminum die casting, powder-coated
Electrical properties		
Voltage range	V	DC 21.6 ... 40
Max. Power consumption (excl. heating)	VA	2
Max. Power consumption: (incl. heating)	VA	10
M-Bus-Voltage (Signal)	V/mA	max. 40 V non-polarized / max. 30 mA
Thermal data		
Ambient $t \leq 95$ (nicht kondensierend) emperature	°C	-10 ... + 50
Relative humidity	%	≤ 95 (non-condensing)
Optional communication modules (input parameters)		
BMZ-Modul Siemens FDnet	V	DC 33 V; max. 10 mA
ADICOS Coupling module 4-20 mA	V	DC 35 V; max. 20 mA
BMZ-Modul Bosch LSN	V	DC 36 V; max. 20 mA
Pre-alarm relay module	V	DC 40 V; max. 10 mA
	V	DC 24 V; max. 20 mA
Sensor data		
Resolution	Pixel	32 x 31
Capture angle	°	53 x 52
Reaction time	s	< 1
Temporal resolution	s	0.1 or 1 (depending on configuration)

Information regarding explosion protection		
Explosion protection class		 II 3G Ex ec nA IIC T4 Gc II 3D Ex tc IIIC T80°C Dc Certified according to ATEX and IECEx
Max. Surface temperature		Group II: T4 Group III: T 80°C
Device group		II, category 3D /3G
Other		
Bending radius cable	mm	> 91,5

9.1 ID Plate

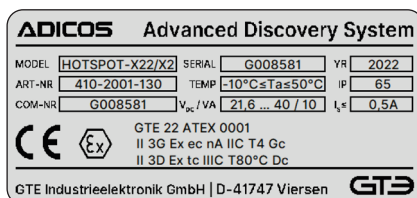

Model	Device model	SERIAL	Serial number (variable)	YR	Year of production (variable)
ART-Nr	Article number (variable)	TEMP	Ambient temperature	IP	Degree of protection
COM-Nr	Communication number (variabel)	V _{DC} /VA	Voltage range / maximum power consumption (heating incl.)	I ₀	Internal fusing (Short-circuit current)
CE marking		Information on explosion protection			

10 Appendix

10.1 ADICOS Mounting Plate

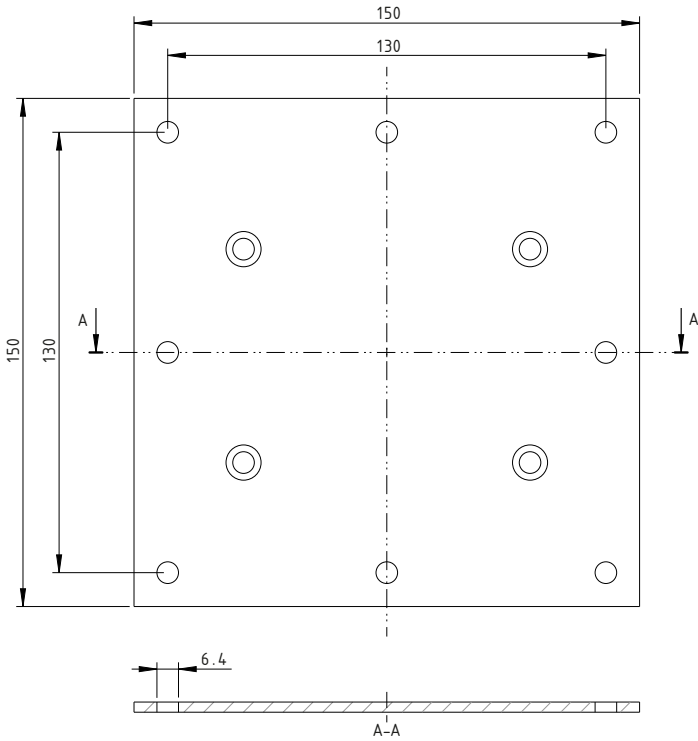

10.2 ADICOS Mounting Bracket